

Obedience (OB) training teaches a dog how to act in a co-operative and controlled way. Emphasis should be put on establishing good contact between the dog and the handler and on achieving the dog's willingness to obey even when at distance from the handler. Handler and dog should display a good overall relationship.

These rules and guidelines have been compiled to promote the obedience sport and to support competing across the borders of nations.

These rules and guidelines are applied at obedience trials in countries where the Kennel clubs have decided to follow them.

Even results from other obedience trials with different performances that meet the corresponding requirements should be acknowledged.

I RULES ON ARRANGING, PARTICIPATING IN, MANAGING AND JUDGING OBEDIENCE TRIAL AND COMPETITIONS

1. Arranging official obedience trials and competitions

Each national FCI member country decides what clubs and organisations are allowed to arrange official obedience trials and competitions.

2. National rules and guidelines concerning obedience trials

It is recommended that the Kennelclubs publish on their website all necessary information concerning national rules, special national requirements, details of their legislation that influence animals entering their country and trials, as well as details such as entry fees and bank accounts, so that competing throughout all FCI member nations can be promoted. It is recommended that the handlers entering a competition should be informed of all necessary details concerning the competition and special national requirements by sending them a memo (data sheet).

3. Eligibility to participate in obedience classes

The eligibility to participate in obedience trials is defined by the regulations of the dog's home country and those of the country where the competition takes place. The national rules state what dogs are allowed to compete in obedience trials (classes 1 & 2 & 3). Eligibility to compete should be published on the website of the country.

The age at which class 1 can be entered should be stated in the national rules of each country. The dog should, however, be at least 10 months if not otherwise stated by the national rules of the country where the competition is arranged or the country in which the dog is registered.

In an international obedience competition (class 3, caciob), or in a Section Winner (SW) or World Winner (WW) championship, it is required that the dog be at least 15 months of age and registered in a studbook or appendix to a studbook recognised by the FCI. Dogs registered with AKC, KC or CKC are allowed to participate but are not eligible for the CACIOB

It is up to every country to decide what national obedience classes are recognised and what

requirements need to be fulfilled before a dog is allowed to compete in a certain class. To participate in an international obedience competition, however, the handler and the dog together should at least once have passed the previous highest obedience class (class II or a class with corresponding exercises) in their own country.

It is up to each country to decide how many times a dog may enter a class after having received its first 1st price. *This information should be available on the national www-pages.* If a dog has once started in a class it can't enter a lower class.

3.1 Health

Dogs that are blind, suffer from contagious diseases or infections or have hookworms, scabies or any other vermin may not participate in obedience trials. Dogs that are taped, stitched or bandaged are not allowed to participate.

3.2 Antidoping and vaccination regulations

The national vaccination regulations and antidoping regulations should be followed according to the dog's home country and those of the country where the trial takes place. These should be published on the website of the country in which the competition takes place.

3.3 Aggressiveness

Aggressive dogs are not allowed to enter the competition premises. The judge will disqualify any dog that attacks or attempts to attack a person or another dog. The incident is noted in the dog's working book and a report must be sent to the kennel club that the dog represents and the kennel club of the arranging country.

3.4 Bitches in season and bitches in breeding

Bitches in season are allowed to compete in accordance to national rules of the country where the trial is held. *This should be published on the website of the country that arranges the trial.* Bitches in season must, however, perform last. They must be kept off the competition premises and nearby surroundings until all other dogs have completed their exercises.

Bitches expected to give birth within four weeks and bitches that have given birth less than eight weeks before the competition date must be excluded

National rules may state a stricter tolerance. This should be informed of on the website of the country that arranges the trial.

3.5 Changes in appearance

Dogs with docked tails or cropped ears or ones that have had some other changes in appearance done for cosmetic reasons' are admitted only if the admittance is in accordance with the legal regulations of the dog's home country and those of the country where the trial is arranged.

All restrictions due to changes in appearance of the dog should be stated in the national rules and should be informed of on the website of the country.

3.6 Spayed or neutered dogs

Spayed or neutered dogs are allowed to compete.

3.7 Checking the dogs

If necessary the judge should check the dogs before they enter the ring.

National rules can require that all dogs are checked.

3.8 Other regulations

If an obedience competition is arranged in association with a dog show, there should be no obligation for the dog be entered in the dog show.

National regulations should define what specific registration and club membership requirements should be fulfilled.

4. Eligibility to judge international obedience competitions

Judges for obedience competitions should have a sufficient training in judging obedience and be licensed by the kennel club of their own country.

In case of inviting a judge from some other country, his/her qualification and language skills should be checked from his/her national Kennel club.

Ineligibility due to the likelihood of bias: *National regulations define ineligibility due to the likelihood of bias.*

5. Chief steward

A chief steward must be appointed for the competition. The chief steward is responsible for the practical arrangements of an obedience competition. The chief steward must have appropriate qualifications. A qualified steward should direct the exercises in classes 2 and 3. It is recommended also in class 1. If competitors from abroad enter the competition, it is recommended that a mutual language for directing the exercises is beforehand agreed upon. In class 3 the steward must be able to conduct the exercises in English or a language mutually agreed upon.

If the exercises are divided to be judged by two or more judges, there should be an equal number of stewards, so that each ring will have at least one steward.

6. Management of the competition

Obedience competitions are under the management of the (chief) judge of the day and the chief steward. If there is more than one judge in a competition, one of the judges is appointed chief judge who will be chairman of the judging team.

If incidents occur that are not dealt with in these regulations and directions, the judge (or team of judges lead by the chief judge) decides how to proceed or how to evaluate.

6. Handler's obligations and dog's equipment

A handler's obligations as a competitor start when the handler enters the competition premises and end after the final prize-giving ceremony. Handlers must follow the rules and directions as instructed. Handlers are expected to be on their best behaviour and appropriately dressed.

The judge may disqualify a handler from the competition if he or she does not abide by the rules or behaves in an unseemly way. The judge's decision is final and no competitor shall impugn the decisions of the judge.

Handlers should report their presence at the competition premises 30 minutes before the competition begins.

It is forbidden to punish the dog.

Only ordinary collars are permitted. Barbed or electric collars and other constraining devices or means, such as muzzles, are forbidden. This restriction goes from the start of the competition till the end.

Blankets, mantles, raincoats, shoes, stockings, bandages, tapes, etc., on the dog are forbidden during the performance.

The handler should have the dog on the left side during and between the exercises. If there is a physical reason or disability, the handler is allowed to have the dog on the right side during or between the exercises. The competitor or team leader of this combination must discuss the arrangement with the referee judge before the start of the competition, however. All judges concerned must be informed and the effect this has on evaluating the performances must be agreed on if there are several judges involved. The exceptional arrangements should be justified and should not be such that they cause disturbance to other dogs and competitors. For example, if a competitor is bound to a wheelchair, he or she should, in group exercises be placed at that end of the line where no other dog is passed than his or her own that is, he is first in line.

8. Dog's behaviour / Disqualification

A dog that at any time during the competition (before, during or after its own performance) bites, tries to bite, attacks or tries to attack people or other dogs, is disqualified from the competition. All points are lost even if the performance has already been completed. In a two-day event, the disqualification is valid also for the second day and thus the dog cannot compete.

The incident is noted in the dog's working book and a report must be sent to the kennel club that the dog represents and the kennel club of the arranging country.

In addition to the actions mentioned above, national regulations should be followed.

9. Other regulations

When the competition ring is being built or has been built for the competition, a handler is not allowed to enter the competition ring together with the dog unless an authorized person (the chief steward or judge) has given permission.

In the group exercises, the minimum number of dogs in a group is three and the maximum six. In a competition where the number of dogs is not divisible by six, two of the groups may consist of seven.

II PRACTICAL ARRANGEMENTS AND EQUIPMENT

Layout, number of competitors, size of the ring and equipment needed

10. Layout of the competition

The judge (chief judge, referee judge, chairman of the judging team) has the right, having consulted the organising committee, to decide in which order the exercises will be done during the competition and how the exercises are grouped together. The order should be the same for all competitors.

11. Time allocated for judging per day and number of competitors

The competition should be so planned that the judging appointment does not take more than approximately five hours per day. *National guidelines of the country where the competition is arranged should be followed.*

It should be noted that the time needed to judge a particular number of dogs depends on the layout of a competition, the steward, the judge and the breeds that have been entered.

Class 1

It is recommended that a judge does not judge more than approximately 30 dogs per day in class 1. Judging 6 dogs takes approximately one hour.

Classes 2 and 3

It is recommended, that a judge does not judge not more than 25 dogs per day in classes 2 and 3. Judging 4 dogs takes approximately one hour.

If more than one judge is appointed, each judge judges the exercises appointed to him for all dogs entering. In this case the number of dogs can be more.

12. Size of the obedience ring and quantities of the exercises

The size of the obedience ring for an indoor competition should be at least 20 m x 30 m in classes 2 and 3 and when the competition is outdoors, the preferred size is at least 25 m x 40 m. In class 1 the ring can be slightly smaller. The ring can also be smaller if the exercises are divided among two or more rings and those exercises requiring less space are grouped together. The ring should be clearly marked. It is up to the judge to decide whether the ring size is acceptable or not. All quantities of the exercises are approximations.

13. Equipment

It is the responsibility of the organising committee to keep the following equipment as well as the regulations and instructions available at the competition premises.

- Charts by which the points awarded are shown should be available.

- A boarded hurdle approximately 1 m wide and adjustable in height from about 10 cm to 70 cm at intervals of 10 cm is required. [Exercise 9 in classes 1&2] In contrast to an agility fence the hurdle should not have side wings. **See figure on page XX**
- A sufficient number of markers and cones must be available to indicate for example the places of the start and end of the exercises, when necessary, and the places of performance such as turning sites, etc. The markers and cones should be such that they can be easily seen and the height of the cones should be of appropriate size. For example the cones for the corners of the square in class 1 (Ex 6) and in class 2 (ex 5) should be approx. 15 cm.

Suitable retrieve objects:

- Three series of wooden dumbbells. Each series includes two dumbbells of equal size. Each series differs in size and weight so as to suite small, middle size and large breeds. The maximum weight of the largest is approximately 450 g. The handler can choose whatever size he prefers, however.
- Metal dumbbells of three different sizes with a maximum weight of approx. 200 g for the largest. The sizes of the dumbbells available should be in proportion to the sizes of breeds (small - medium - large). The handler can choose whatever size he prefers, however.
- Wooden objects approx. 2 cm x 2 cm x 10 cm for classes 2 and 3. The number of objects needed is six times the number of competing dogs.

III AWARDS AND MOVE-UPS

Class 1

1 st prize	224 – 280 points	80 % Excellent
2 nd prize	196 – under 224points	70 % Very good
3 rd prize	140 – under 196 points	50 % Good

Class 2

1 st prize	256 – 320 points	80 % Excellent
2 nd prize	224 – under 256 points	70 % Very good
3 rd prize	192 – under 224 points	60 % Good

A dog that has achieved excellent in a class (in any country) is allowed to move up to the next class

It is up to the national rules to state how many starts are allowed in a class after the dog has achieved excellent.

It is up to the national rules to decide what trophies or diplomas are awarded.

A dog is, however, allowed to compete in a class until it has achieved 3 x excellent / country.

IV EXERCISES AND COEFFICIENTS

It is recommended that national obedience programmes include a novice class, that the dogs should pass before entering class 1.

The rules and guidelines for class 3 are published elsewhere.

Class 3 can be applied from the FCI as an international competition where a CACIOB is awarded or it can be applied as a national competition.

CLASS 1	Exercise	Coeff.
1.	Lying in a group for 2 minutes, handlers out of sight	3
2.	Heelwork	3
3.	Stand under march	2
4.	Recall	3
5.	Sit under march	2
6.	Send away into a square	4
7.	Retrieve	3
8.	Distance control	3
9.	Jumping over a hurdle	3
10.	General impression	2
	Σ	28
	1 st prise 80 % excellent 2 nd prise 70 % very good 3 rd prise 50 % good	
CLASS 2	Exercise	Coeff.
1.	Sitting in a group for 1 minute handlers in sight	2
2.	Heelwork	3
3.	Stand and sit under march	3
4.	Recall with stand	4
5.	Send away with down and recall	4
6.	Directed retrieve	3
7.	Scent and retrieve	4
8.	Distance control	4
9.	Jumping over a hurdle and retrieving a metal or wooden object	3
10.	General impression	2
	Σ	32
	1 st prise 80 % excellent 2 nd prise 70 % very good 3 rd prise 60 % good	

CLASS 3	International rules	
----------------	---------------------	--

	CACIOB may be awarded if the competition is applied from the FCI as an international competition	
	Exercise	Coeff.
1.	Sitting in a group for 2 minutes handlers out of sight	3
2.	Lying in a group for 4 minutes handler out of sight	2
3.	Heelwork	3
4.	Stand, sit and down under march	3
5.	Recall with stand and down	4
6.	Send away with directions, down and recall	4
7.	Directed retrieve	3
8.	Jumping a hurdle and retrieving a metal object	3
9.	Scent and retrieve	3
10.	Distance control	4
	Σ	32
	1 st price 80 % excellent 2 nd price 70 % very good 3 rd price 60 good	

V REGULATIONS AND GUIDELINES FOR PERFORMING AND JUDGING THE EXERCISES

The regulations and guidelines for performing and judging the exercises comprise of

- A) a general part which concerns performing and judging all exercises in class 1 and 2 and
- B) a part which describes the performing and judging of the individual exercises.

If not otherwise stated in the individual exercises, the general regulations and guidelines for performing and judging the exercises are applied to all exercises.

If incidents occur that are not covered in these regulations and directions, the judge decides how to proceed or how to evaluate. The judge's decision is final and no competitor shall impugn the decisions of the judge.

Points awarded

The obedience performances are graded as follows:

0 – 5 – 5½ – 6 – 6½ – 7 – 7½ – 8 – 8½ – 9 – 9½ – 10.

Disqualification leads to termination of the performance and loss of all points awarded. The dog may not continue with the remaining exercises of the competition.

Failing an exercise leads to loss of all points in the specific exercise. The dog may continue with the remaining exercises.

A) General guidelines for judging and performing all exercises in class 1 and 2

Performing the exercises

- The judge can choose in what order the exercises are performed. The order should be the same for all competitors.
- National rules can state that all dogs must be checked before they are allowed to enter the ring and might also state that the judge should be allowed to handle/touch the dogs.
- The exercises begin and end with the dog in heel position. The heel position is defined as the sitting position at the handler's left side.
- All exercises begin when the steward has directed the handler and dog to the starting point and the dog sits in starting position and the steward has announced "The exercise begins" or "The exercise starts".
- The handler should bring his/her dog to heel position at the starting point and be ready to start the exercise within a very short time. In class 1 the tolerance can be slightly more than in classes 2 and 3 where the handlers should be prepared to have their dogs in heel position and start the exercise very shortly after having reached the starting point.
- All exercises are over when the steward has announced "Exercise over" or "Thank you".

- In all exercises, if not otherwise stated in the exercises, the steward gives in all phases of the exercise the permission to the handler to command the dog, even if it is not systematically written down in all exercises.
- It is up to the handler to decide whether or not to give a second command and when to give it.
- The steward's commands described in these regulations are just examples. It is important that the commands are clear to the handlers.
- It is not allowed to point out places and directions to the dog before or during exercises (other than those relating to the on-going exercise, if such are allowed). Such activity will lead to failure of the exercise.
- The dog should be on the handler's left side between the exercises. The dog does not have to be in heel position and under command, but it should be beside the handler and under control. If for some reason or other there is a delay when moving from one exercise to the next, it is allowed to command the dog down, but it should not be recalled from this position to continue with the exercises.
- The handler should move normally using straight paths. Indefinite or ambiguous movement, exaggerated gestures, signals or body language and unnatural movements of the extremities are penalised. Turns and turnabouts should be 90° and 180° and after turnabouts the handler should return approximately using his original path.
- In class 1 the handler may enter the ring with the dog on the leash. During the whole performance the handler must keep the leash invisible to the dog or the handler may leave it at the steward's desk. He may put the leash on the dog after the performance when he leaves the ring.
- In class 2 the handler must leave the dog's leash outside the ring or at the steward's table. This applies to all exercises.
- Tit-bits or playing tools such as balls or toys are not allowed in the ring, neither during nor between exercises. If the judge observes that a competitor has or uses tit-bits or playing tools in the ring, he or she will be disqualified.
- The handler is not allowed to touch the dog or stroke it or give other forms of encouragement during the exercises. Such behaviour will result in failure of the exercise. Slight encouragement is allowed after the exercise has been completed. In the case of excessive encouragement, too enthusiastic inspiring, playing or fooling around, jumping into the arms of the handler, threading around the handler's legs, etc., the judge will warn the competitor and note this behaviour in the general impression. In case of a second incident, the dog is disqualified.
- The judge has the right to stop an exercise if the dog shows obvious incapability or unwillingness to perform it. Such an exercise is failed.
- The judge has the right to bar a dog from further participation in the competition if it isn't functioning properly or if it is causing disturbance by continuous barking or whining. In case of barking or whining the judge can give a first warning. If the behaviour continues the judge will disqualify the dog. The same holds for continuous disturbance by barking or whining between exercises.

- In the recall (and retrieving) exercises the dog is allowed to come and sit in front of the handler. The dog must then, on command (after permission from the steward), quickly take its heel position, passing the handler very closely.
- In the recall and retrieving exercises, the judge does not need to know how it was intended that the exercise be performed with regards to taking the heel position directly or after sitting in front. If the exercise is elegantly performed, full points can be awarded regardless of what was intended.

Retrieving exercises:

- In all retrieving exercises the dog is allowed to sit in front of the handler and there deliver the object on command (after permission from the steward). The dog must then, on command (after permission from the steward), quickly take its heel position, passing the handler very closely.
- If a dumbbell is thrown to an unsatisfactory place (too short a distance, outside the ring), it must be thrown again. This however results in a reduction of 2 points. If the second throw is not successful the exercise is failed.
- It is not allowed to let the dog take hold of the object / dumbbell before the exercises. If this occurs, not more than 5 points can be awarded.

Commands and hand signals:

- Commands are verbal commands. Hand signals can substitute a verbal command or be given simultaneously with a verbal command. If so, it will be stated in the exercise. When using hand signals they should be short and not outlast a verbal command and not include any other body language. One hand or two hands may be used.
- The concept body language means moving your body (not necessarily taking steps), twisting or turning the body, the head or shoulders as well as giving signals with your feet. This is penalized according to graveness and situation. Taking steps when commanding will disqualify the exercise.
- In exercises where commands or signals are allowed, the handler must inform the judge before the exercise commences if hand signals will be used. This is not necessary if both commands and signals are allowed.
- The command “Stay” is allowed in exercises in which the handler leaves the dog or turns away from the dog.
- Hand signals are never allowed when the dog is beside the handler in heel position. This is severely penalised with a reduction of 2-4 points depending on strength, situation and duration. If body language is included the reduction is always stricter.
- The commanding words given in these regulations are recommendations. Other sufficiently short words are acceptable. The dog’s name may be combined to the command in the recall exercises / recall situations. The name and the command have to be tied closely together so that the name and command do not give an impression of two separate commands.

Leaving the handler

- If a dog leaves the ring during or between the exercises being out of control, it is disqualified (classes 2 & 3)
- In class 1, if the dog leaves the ring being out of control, the handler is allowed to call the dog twice. If it returns, they may continue, but this will be noted in the general impression and severely penalized. The exercise concerned is failed. If the dog leaves the ring another time, it is disqualified.
- If the dog leaves the handler during an exercise (interrupts the exercise) and is out of control, the handler may call the dog (not more than twice) without leaving his or her position. If the dog returns to the handler the exercise is failed, but dog and handler can continue with the next exercise, but this will be severely penalized (general impression). If the dog does not return within the second command, dog and handler are disqualified. If the dog leaves a second time, disqualification follows.

Judging the exercises

- Judging of an exercise starts when the handler and dog have taken their position (dog in heel position) at the starting point and the steward says "The exercise starts". Judging of an exercise ends when the steward has announced "Exercise over" or "Thank you".
- All deviations from the ideal should be penalised: all extra commands, double commands, body language, deviations of heel position, deviations from parallel movement, etc.
- A general rule is that, for a second command 1-2 points should be deducted and a third command fails the exercise (or a part of it).
- A dog that barks, even occasionally in an exercise, should be penalised. If the dog barks extensively or continuously the exercise is failed. If the barking is continuous and is repeated in several exercises the performance is disqualified. The same holds for whining.
- Barking or whining during the exercise must always be penalised, even if there is only one very short bark in the beginning of the exercise (maybe expressing enthusiasm), at least 1 point should be reduced.
- If the handler takes steps when giving commands, the exercise is failed.
- If a dog anticipates the command (i.e. does not keep the heel position properly; jerks, stands up, but does stake steps forward), when starting the exercise, not more than 8 points can be awarded.
- In class 1, if the dog leaves the handler (starts the exercise) after the exercise has started (in exercises where the dog is sent away from the handler) but before the command of the handler (for example on command of the steward), the handler may call the dog once. If it returns and fulfils the exercise max 6 points can be awarded. If it does not return the exercise is failed.
- In class 2 if the dog leaves the handler (starts the exercise), before command, there is no

possibility for recall, the exercise is failed.

- All punishment of the dog, leads to disqualification.
- If the handler touches the dog during the exercise, the exercise is failed. This may lead to a warning. If touching the dog during or between exercises, can be interpreted as punishment, dog and handler are disqualified.
- Controlling the dog by the collar between exercises leads to a warning.
- If a dog touches the handler (slightly, lightly) in the recall or retrieving exercises when sitting in front of the handler or moving to side of the handler, 1-2 points should be deducted. If it bumps into / collides with the handler, not more than 7 points should be awarded.
- In judging speed, the breed should be taken into consideration. The ideal for all breeds is not the same. When a dog reacts on the commands instantly and willingly, moves typically to his breed, keeps his pace and shows an interest in what he is doing, he should be awarded with full points if there are no lowering mistakes.
- If the dog does not sit calmly beside the handler at the start of an exercise, not more than 8 points can be awarded.
- If a dog does not take its heel position (sit) at the end of an exercise not more than 7 points can be awarded.
- If the dog does not take the starting position of an exercise (i.e. sit or down), the exercise is failed.
- If the dog relieves itself in the ring:
 - in class 1 during an exercise, the exercise is failed (0 points) and the general impression is failed (0 points).
 - in class 1 in-between the exercises, the general impression is failed (0 points)
 - in class 2 during or in-between exercises, the dog is disqualified.

B) Guidelines for performing and judging the exercises in classes 1 and 2

CLASS 1

EXERCISE 1. Lying in a group for 2 minutes, handlers out of sight [Coeff. 3]

Commands: “ Down”, “Stay”, “Sit”

Performance: The handlers should take their places in a row with their dogs on leash and command their dogs to heel position. The dogs should sit in heel position in a row at approximately 3 metres distance from each other. The lying down on command from heel position is performed one by one. The dogs should be commanded to lie down from left to right and to sit up from right to left so that the first one to lie down is the last one to sit up. The steward tells when to give the command. The handlers walk out of sight of the dogs together and stay hidden for a period of two minutes. The two-minute period starts when all the handlers are out of sight. When two minutes have elapsed, the handlers are instructed to line up inside the ring border and on instruction of the steward to walk together up beside their dogs. The handlers are told to, one by one, command their dogs to heel position. There should be at least three dogs in a group but not more than six. The handlers should be reminded that they are not to give their commands too loudly. This might influence the other dogs and will be strongly penalised.

Directions: The steward announces “Uncouple your dogs” and then “Exercise starts”, after the dogs have been unleashed. The exercise starts here for all competitors in the row. The steward then commands the first handler to command his/her dog to lie down. The exercise ends when the handlers have returned to their dogs and all dogs have taken their heel position and the steward has announced “Exercise over”.

A dog that fails to lie down (two commands), stands up or sits up or crawls more than its own body length before the time is out, fails the exercise (0 points). All movement should clearly reduce points. If the dog barks 1-2 times, 1-2 points are deducted; if it barks most of the time, the exercise is failed (0 points). Restlessness, such as shifting weight from one side to another, should be penalised.

The dog is allowed to turn its head and look around, and it is allowed to show interest if there is distraction or noise inside or outside the ring. This must not, however, give an appearance of restlessness or anxiety. If a dog stands up and goes close to another dog, so that there is fear for a fight, the exercise must be stopped and then resumed for all dogs except the dog that caused the disturbance.

If the dog reacts (lies down or sits up) before the handler’s command (e.g. on a neighbour’s “down” or “sit” command), not more than 8 points can be awarded. If the dog has lied down/sat up before it is commanded and it changes its position on its own or by command (rises back up/goes back down), not more than 7 points can be awarded.

Not more than 7 points can be awarded if a dog lies on its side (flank).

If the dog sits or stands up after the two-minute period is over, and the handler has reached the inside of the ring, not more than 5 points can be awarded, but if it then moves as well, the exercise is failed.

EXERCISE 2. Heelwork off leash**[Coeff . 3]****Command:** "Heel"

Performance: Heelwork is tested at normal pace in conjunction with turns to the left and right and turnabouts and halts. Heelwork is also tested in fast pace, but only right turns should be included in fast pace. The dog must also be tested when the handler moves two or three steps forward and backward. The unleashed dog should willingly follow the handler, walking on the handler's left side, with its shoulder level with the handler's left knee and following the handler in a parallel line. The handler should move his arms in a natural way during the exercise.

The handler can choose to do the turnabouts to the left or to the right. The "German turnabout" is equally acceptable, i.e., the dog is allowed to circle around the handler on the right side, but very tightly. The handler should, when making a turnabout (180° turn), return approximately along the same line that he came. Turns to the left and right should be right angles (90°). The handler should not turn his head, should not twist his shoulders and should not use body language.

The "heel" command may be given at every start, when changing speed and when taking steps. When the handler stops, the dog should take the heel position immediately and without command.

All dogs in one test or competition should do the heelwork according to the same scheme.

Directions: A dog that leaves the handler or follows the handler at a distance of more than half a metre during the major part of the exercise is failed. If the dog moves slowly, only 6-7 points should be given. Lack of contact and extra commands are mistakes. An imperfect direction (not parallel) of the heel position should result in loss of about 2 points. A dog that walks very near to the handler so that it disturbs the handler should be penalised, even more if the dog leans and touches the handler.

EXERCISE 3.

Stand under march

[Coeff . 2]

Commands: “Heel”, “Stand”, “Sit”

Performance: Handler and dog leave the starting position walking in a straight line at normal pace. After about 10 metres the handler commands the dog without stopping, to stand and the dog must stop immediately. The handler walks about 10 meters (place indicated f.ex. by a marker or cone), turns around and stands facing the dog. After three seconds, on the steward’s permission and the handler returns to the dog and commands the dog to heel position. All phases of the exercise are done on steward’s permission.

Directions: If the dog stops in a wrong position, changes a correct position before the handler has turned around, stands before command, needs an extra command or if the handler stops before / when commanding the dog, no points can be awarded. To get any points the dog should not move more than one body length after the command.

If the dog changes a correct position after the handler has turned, not more than 7 points should be awarded. If the handler slows down /changes pace / speed before his command not more than 7 points can be awarded. Hand signals and body language on the stand command are grave mistakes, and will be severely penalised, depending on their strength and duration with a reduction of 3-5 points.

In judging, attention should be paid to the heelwork as well. For bad heelwork the reduction should be 1-2 points. Moving and stopping slowly or not stopping in a straight position are mistakes. The reduction should be 1-4 points.

EXERCISE 4.**Recall****[Coeff . 3]****Commands:** “Down” “Come” (once) (“Heel”)**Performance:** The dog is placed in down position (on steward’s permission) and the handler starts walking (after steward’s permission) 20 – 25 m in the indicated direction. On permission from the steward, the handler recalls the dog. The dog’s name may be combined with the recall command, but name and command must be well combined together and may not give the impression of two separate commands.**Directions:** It is important that the dog responds willingly to the recall command. The dog should move at good speed and keep its pace, at least a fast trot. Slow movement is a mistake. The breed should be taken into consideration in judging the speed. If more than one recall command is given, the highest score is 7. A third recall fails the exercise. If the dog moves more than one body length before the recall command, the exercise is failed. If the dog stands or sits up or moves less than one body length before told, not more than 8 points can be awarded.**EXERCISE 5.****Sit under march****[Coeff . 2]****Commands:** “Heel”, “Sit”**Performance:** Handler and dog leave the starting position walking in a straight line at normal pace. After about 10 metres the handler commands the dog, without stopping, to sit and the dog must sit down immediately. The handler walks about 10 meters to a place indicated f.ex. by a marker or cone, and turns around (independently) and stands facing the dog. After approximately three seconds the handler returns to the dog and commands the dog to heel position. All phases of the exercise except turning around are done on steward’s permission.**Directions:** If the dog stops in a wrong position, changes a correct position before the handler has turned around, sits before command, or needs an extra command, or if the handler stops before / when commanding the dog, no points can be awarded. To get any points the dog should not move more than one body length after the command.

If the dog changes a correct position after the handler has turned, not more than 7 points should be awarded. If the handler slows down /changes pace / speed before his command not more than 7 points can be awarded. Hand signals and body language on the sit command are grave mistakes, and will be severely penalised, depending on their strength and duration with a reduction of 3-5 points.

In judging, attention should be paid to the heelwork as well. For bad heelwork the reduction should be 1-2 points. Moving and sitting slowly or not sitting straight are mistakes. The reduction should be 1-4 points.

EXERCISE 6.**Send away to a square (15 m away)****[Coeff . 4]**

Commands: “Forward”, (“Stand”), “Down”, “Sit”

Performance: The dog is sent to a square of 3 m x 3 m at approximately 15 metres distance from the starting point (to the middle of the square). When the dog reaches the square, the handler commands the dog down. The square should not be situated less than approximately 3 – 5 meters from the ringside border. Cones mark the square at each corner. Visible lines (e.g., tape, chalk lines) should connect the cones on their outer side. When told, the handler walks up beside the dog and commands (after permission from the steward) it in heel position. See Figure. A “stand” command may be used before the “down” command.

Directions: The dog’s willingness to follow the command, the dog’s tempo and a straight route should be emphasized. To get 10 points, the handler should not use more than 4 commands during this exercise, the fourth command being a stop command in the square. The dog must follow the commands (e.g., if a stand command is given in the square). An option is to use only the down command when the dog has entered the square and thus use only three commands. If the dog moves very slowly, only about 7 points should be given.

If the dog acts on his own points are reduced. If the handler moves forward (takes steps in any direction) while giving the commands, the exercise is failed (0 points). If there is excess action (body language), not more than 8 points should be given.

To get points, the dog’s whole body, except for the tail, must be inside the square. If the dog sits or lies down outside the square, it cannot be redirected.

The exercise is failed if the dog moves out of the square before the end of the exercise. If the dog creeps in the square, not more than 7 points can be awarded. If the dog changes position before the handler has reached it, not more than 6 points can be awarded.

The exercise is failed if one of the stand or down commands has to be given a third time. The penalty for extra directing commands depends on their strength and the dog’s willingness to obey the commands. Not more than 8 points can be awarded, if the dog rises to sit or stand before command when the handler is beside the dog.

It is not allowed to show the dog directions at the starting point or to show the square to the dog before the exercise. These lead to failing the exercise.

EXERCISE 7.

Retrieve

[Coeff . 3]

Command : “Retrieve” and “Release”, (“Heel”)

Performance: The steward announces the start of the exercise and hands the handler the wooden dumbbell. The handler throws the dumbbell on the steward’s command to a distance of at least 10 m. When instructed, the handler commands the dog to retrieve the dumbbell. Three sizes of dumbbells should be available. The size of the dumbbell should be in relation to the size of the dog but the handler is free to choose the size. The organiser should have three different sizes of wooden dumbbells available, the largest weighing 450 g at the most.

Directions: Emphasis should be on the dog’s willingness to follow the commands, the dog’s tempo and its taking the shortest ways to the dumbbell and back.

Dropping the dumbbell:

If the dog drops the dumbbell, but picks it up on its own initiative, not more than 7 points can be awarded. If an extra “retrieve” command has to be given before the dog picks up the dropped dumbbell, the maximum is 6 points. If the dog drops the object beside the handler and the handler picks it up without taking a step, 5 points can be awarded presuming the dog takes the heel position correctly. If the object is dropped, due to the handler’s carelessness after the release command, not more than 7 points can be awarded.

Chewing or biting on the dumbbell

Chewing or biting on the dumbbell is penalised by a reduction in points. If chewing is extensive not more than 5 points can be awarded. Very extensive chewing or breaking the dumbbell results in failing the exercise (0 points). No penalty should be given, however, if the dog once takes a better grip on the dumbbell.

EXERCISE 8.**Distance control
Sit /down, 4 changes****[Coeff . 3]****Commands:** “Down” “stay”, “Sit”, “Down” and / or hand signals.

Performance: The handler commands (on steward’s command) his/her dog in down position at the starting point. The handler leaves the dog and moves to an assigned place approx. 5 m from the dog. The dog should change positions 4 times (sit/down) and remain in its original place. The order of taking the positions should only be sit - down (two times) and thus the last command for changing position should be “down”. The steward shows the handler in which order the dog should change position using written signs or drawings or an electrical display board. The steward should not be able to see the dog when displaying the instructions and keep a distance of approximately 3 – 5 meters from the dog. The steward should change the sign about every 3 seconds. The handler may use both voice commands and hand signals, but they must be short and used simultaneously. After the last down command, when instructed, the handler returns to the dog and commands it to sit. A boundary is marked in back of the dog by an imaginary line connecting two markers.

Directions: Emphasis should be on how much the dog moves, the speed at which positions are changed, the clearness of the positions and how well the positions are held. To get any points, the dog should not move in total more than one body length from the starting point (in any direction). All movements are summed. If the dog misses one position of the four, not more than 7 points should be given and if he misses two positions the exercise is failed. If the dog sits up before the handler returns, not more than 8 points should be given. Extensive use of voice and exaggerated or continuous / long lasting hand signals are penalised. A third command on a position may be given, but this position is lost. The first time a second command has to be given on a position -2 points is reduced. The next ones are -1 point.

EXERCISE 9.**Recall with jumping over a hurdle****[Coeff . 3]****Commands:** “Stay”, “Come or jump”, (“Heel”)

Performance: The handler leaves (on steward’s command) the dog sitting in front (2 - 4 m) of the hurdle, walks around the hurdle to the other side (approximately 2 - 4 m) and recalls the dog to jump on the steward’s command. The dog should jump and take the heel position. The height of the hurdle should be approximately the shoulder height of the dog. The maximum height is, however, 50 cm.

Directions: The exercise begins when the handler leaves the dog and ends when the dog has taken heel position and the steward has announced “exercise over”. Emphasis should be on the dog’s willingness to follow the commands, the dog’s tempo and taking the shortest way to the handler. If the dog touches the hurdle even slightly when jumping, the maximum score is 8 points. If the dog supports itself on the hurdle, if the hurdle is turned over or if the dog doesn’t jump, the exercise is failed.

EXERCISE 10.

General impression

[Coeff . 2]

Directions: When judging the general impression the dog's willingness to work and obey the commands are essential. Accuracy and precision are important, as well as natural movements of both handler and dog. To get a high score both handler and dog must work well as a team, show mutual enjoyment of working together and good sportsmanship. The activities during and between the exercises influence the score for the general impression.

If the dog leaves the ring or if it relieves itself in the ring no points can be awarded for the general impression. If the dog is out of control and leaves the handler during or between the exercises (even once), but stays in the ring not more than 5 points can be awarded.

CLASS 2

EXERCISE 1.

Sitting in a group Handler in sight, 1 minute

[Coeff . 2]

Commands: “Sit”, “Stay”

Performance: The dogs are sitting in heel position in a row at approximately 3 metres distance from each other. When told, the handlers leave the dogs and walk 20 m and turn around facing the dogs. The handlers stand in a natural position in sight of the dogs for 1 minute. The handlers are then told to walk up beside their dog so that the dog is in heel position. There should be at least three dogs in a group, but not more than six.

Directions: A dog that stands up, lies down or moves more than its own body length fails the exercise (0 points). All moving reduces points. If the dog barks 1-2 times, 1-2 points are withdrawn; if it barks most of the time, the exercise is failed (0 points). Restlessness, such as shifting weight from one side or one foot to another, should be penalised. The dog is allowed to turn its head and look around, and it is allowed to show interest if there is distraction or noise inside or outside the ring. This, however, should not give an appearance of restlessness or anxiety. If the dog lies down or stands up after the one-minute period is over, not more than 5 points can be awarded. If a dog stands up and goes close to another dog, so that there is fear for a fight, the exercise must be stopped and then resumed for all other dogs except the dog that caused the disturbance.

EXERCISE 2.

Heelwork off leash

[Coeff . 3]

Command: "Heel"

Performance: Heelwork is tested at different speeds in conjunction with directions, turns and turnabouts and halts. The dog must also be tested when the handler moves two or three steps forward and backward. The unleashed dog should willingly follow the handler, walking on the handler's left side, with its shoulder level with the handler's left knee and following the handler in a parallel line. The handler should move his arms in a natural way during the exercise.

Heelwork is tested in normal, slow and fast pace together with turns, turnabouts and halts. The handler can choose to do the turnabouts to the left or to the right. The "German turnabout" is equally acceptable, i.e., the dog is allowed to circle around the handler on the right side, but very tightly. The handler should, when making a turnabout (180° turn), return approximately along the same line that he came. Turns to the left and right should be right angles (90°). The handler should not turn his head, should not twist his shoulders and should not use body language.

The "heel" command may be given at every start, when changing speed and when taking steps. When the handler stops, the dog should take the heel position immediately and without command.

All dogs in one test or competition should do the heelwork according to the same scheme.

Directions: A dog that leaves the handler or follows the handler at a distance of more than half a metre during the major part of the exercise, fails the exercise. If the dog moves slowly, only 6-7 points should be given. Lack of contact and extra commands are mistakes. An imperfect direction (not parallel) of the heel position should result in loss of about 2 points. A dog that walks very near to the handler so that it disturbs the handler should be penalised, even more if the dog leans and touches the handler.

EXERCISE 3.

Stand and sit under march

[Coeff . 3]

Commands: “Stand”, “Sit”, “Heel” (3 times)

Performance: Under march the handler commands and leaves the dog, on instruction of the steward, in a standing and in a sitting position.

Handler and dog leave the starting position in a straight line at normal pace. After about 10 meters, the handler commands (on steward’s command) the dog to stand and the dog must stop immediately. The handler walks about 10 meters and turns around on the steward’s command and returns towards the dog along a parallel path that he/she left, passes the dog (1-2 m) at a distance of approximately ½ a meter, turns around (on steward’s command) and returns to the dog, takes the dog along without stopping, continues to walk, approximately 5 meters, takes a turn left or right (on steward’s command) and after having walked approximately 10 meters, commands the dog to sit and performs the exercise as in the first part. After having taken the dog along from the sitting position, handler and dog should continue to walk approximately 5 meters. Handler and dog stop on the steward’s command and the dog takes its heel position.

The corners should be 90°, not rounded off.

All phases (starts, stops, turns) of the exercise are done after the steward’s permission.

Directions: If the dog stops once in a wrong position (e.g., sitting instead of standing), not more than 7 points can be awarded. If the dog misses one position (does not stop at all), not more than 6 points can be awarded. To get any points for a given position the dog should not move more than one body length after the command, and take the commanded position (stand, sit) before the handler has turned around. A second command is not allowed on the positions. It leads to a loss of the position. To get points for the exercise, at least one position must be performed.

In judging, attention should be paid to the heelwork as well. For bad heelwork the reduction should be 1-2 points. Moving, standing and sitting slowly or not standing or sitting straight are mistakes as well as turning to look. The reduction should be 1-4 points.

Hand signals and body language on the stand and sit commands are grave mistakes, and will be severely penalised, depending on their strength and duration with a reduction of 3-5 points.

EXERCISE 4.

Recall with stand

[Coeff . 4]

Commands: “Down”, “Stay” or hand signal, “Come” (2 times)
 (“Heel”) [Hand signals: one hand or both hands can be used]

Performance: The dog is placed in down position and the handler walks approx. 25 – 30 m in the indicated direction. On permission from the steward, the handler recalls the dog. The handler orders the dog to stand when the dog has covered approximately half of the distance. When told, (after approximately 3 seconds) the handler recalls the dog again to heel position. The steward tells the handler only when to recall the dog. The handler gives the stop command independently at the marker. A verbal stop command or a hand signal is allowed. The dog’s name may be combined with the first recall command, but name and command must be well combined together and may not give the impression of two separate commands.

Directions: It is important that the dog responds willingly to all recall commands. The dog should move at good speed and keep its pace, at least a fast trot. Slow movement is a mistake. The breed should be taken into consideration in judging the speed. The dog should at once, on command, begin its stop. When evaluating the stop, the speed of the dog should also be considered. There can be some tolerance on the actual stopping for fast dogs, but not for slow dogs. To get full points (for a stop) not more than one body length can be exceeded from the time of command to the stop. To obtain any points (for a stop) not more than 3 body lengths can be exceeded. If more than 2 recall commands are given, the highest score is 6. A third recall on a position results in failure of the exercise as well as two recalls on both positions. If the dog misses the position (stops after 3 body lengths) no more than 7 points can be awarded. If there is no attempt to stop, the exercise is failed. If the dog stops in a wrong position not more than 7 points can be awarded. If the dog sits or stands up before the first recall command, not more than 8 points can be given. If the dog moves more than one body length before the first recall command, the exercise is failed.

EXERCISE 5.**Send away to a square down and recall****[Coeff . 4]**

Commands: “Forward”, [“Right/left” and/or hand signal], (“Stop”), “Down”, “Come”.

Performance: The handler is told to direct the dog to a 3 m x 3 m square at approx. 25 metres from the starting point (middle of the square). The square should be situated not less than approx. 3 – 5 meters from the ringside borders. Cones (approx. 10 - 15 cm) mark the square at each corner. Visible lines (e.g., tape, chalk lines) should connect the cones on their outer side. When the dog reaches the square, the handler commands the dog down. When told, the handler walks forward in the direction of the right-side cone. Approximately 2 m from the cone, the handler is told to turn left and after approximately 3 m the handler is told to turn left, back towards to the starting point. After another 10 m the handler is told to recall the dog while continuing to walk towards the starting point. Having reached the starting point the handler is told to stop.

Directions: The dog’s willingness to follow directions and commands, the dog’s tempo and straight route should be emphasised. To get 10 points, the handler should not use more than 4 commands during this exercise, the fourth command being a stop command in the square. The dog must follow the commands (e.g., if a stand command is given in the square). An option is to use only the down command when the dog has entered the square and thus use only 3 commands.

If the handler moves forward (takes steps in any direction) while giving the commands, the exercise is failed (0 points). If there is excess action (body language) from the handler, not more than 8 points should be given. If the dog acts on his own, this is penalised (e.g. if the dog stops or lies down without a command). If the dog lies down outside the square the exercises failed. If the dog is already down, no redirecting command is allowed. To get points, no part of the dog may be outside the markings of the square, except for the tail.

The exercise is failed if the dog rises to sit or stand before the handler’s second turn. Not more than 5 points can be awarded if the dog rises (to sit or stand) after the handler’s second turn before it is recalled. If the dog moves in the square without rising, not more than 7 points can be awarded. If it moves and crosses the border before recall, the exercise is failed. If the dog moves very slowly, only about 6 points should be given.

A second recall, stop or down command is penalised (- 2 points/command). The exercise is failed if even one of these commands has to be given a third time. Hand signals are only allowed if the dog has to be directed. A hand signal is penalised if given when the dog is beside the handler (-2 p) . The penalty for extra directing commands depends on their strength and the dog’s willingness to obey the commands. It can be 1-2 points/command.

It is not allowed to show the dog directions at the starting point or to show the square to the dog before the exercise. These lead to failing the exercise.

EXERCISE 6.**Directed retrieve****[Coeff . 3]**

Commands: “Heel”, “Stand”, “Right/left” and/or arm signal, “Retrieve”, “Release” (“Heel”)

Performance: Handler and dog stand at the starting point facing a cone at a distance of approximately 5 m. The steward places two wooden dumbbells in a row approx. 10 m apart from each other so that they are easily seen. The dumbbell that is drawn (left or right) is set down first. The cone is situated approximately 10 m from the centre of the imaginary line between the dumbbells and the starting point is approximately 15 m from the line. The handler is told to walk with his dog from the starting point to the cone and place the dog in a standing position by the cone (within a radius of one meter) facing the starting point, where he leaves the dog and returns to the starting point. The handler should not stop when leaving his dog. After about 3 seconds, the handler is told to direct the dog to the correct dumbbell, determined by draw, and the dog should retrieve and deliver the dumbbell correctly.

Three sizes of dumbbells should be available (max about 450 g), suitable for different breeds. The size of the dumbbell should be in relation to the size of the dog but the handler is free to choose the size.

Directions: Emphasis should be on the dog’s willingness to follow the directive commands, the dog’s tempo and its taking the shortest way to the correct dumbbell. Showing the dog directions or touching the dog at the starting point will lead to failing of the exercise. To obtain points for this exercise, the dog should remain standing at the cone until commanded forward. A dog that lies down or sits at the cone, cannot get more than 8 points. If the dog moves more than one body length from its standing position before command the exercise is failed.

If the dog goes to the wrong dumbbell, but is directed to the correct one and the dog brings the correct one, 6 points can be awarded. If the wrong dumbbell is picked up the exercise is failed (0 points).

The penalty for extra directing commands depends on their strength and the dog’s willingness to obey the commands. It can be 1-2 points/command.

Dropping the dumbbell:

If the dog drops the dumbbell, but picks it up on its own initiative, not more than 7 points can be awarded. If an extra “retrieve” command has to be given before the dog picks up the dropped dumbbell, the maximum is 5 points. If the dog drops the object beside the handler and the handler picks it up without taking a step, 5 points can be awarded presuming the dog takes the heel position correctly. If the object is dropped, due to the handler’s carelessness after the release command, not more than 7 points can be awarded.

Chewing or biting on the dumbbell

Chewing or biting on the dumbbell is penalised by a reduction of 2-3 points. If chewing is extensive not more than 5 points can be awarded. Very extensive chewing or breaking the dumbbell results in failing the exercise (0 points). No penalty should be given, however, if the dog once takes a better grip on the dumbbell.

EXERCISE 7. Scent discrimination and retrieve

[Coeff . 4]

Commands: “Seek/retrieve”, “Release”, (“Heel”)

Performance: At the start of this exercise the steward gives the handler a wooden retrieve article (10 cm x 2 cm x 2 cm), on which the handler marks an identification sign or which is marked beforehand with some identification. The handler can keep the article in his/her hand for approximately 10 s. The dog is not allowed to touch or scent the article at this stage. The steward tells the handler to hand over the article and to turn around. The handler decides whether the dog does or does not see when the articles are positioned. The steward walks to place the wooden articles (the handler’s one and five other similar ones), without touching any of them, on the ground or floor at a distance of about 10 metres from the handler. The articles are placed in a circle or horizontal line at a distance of approximately 25 cm from each other. The handler is then told to turn around and to command the dog to retrieve the marked article. The dog should find the handler’s article, retrieve it and deliver it to the handler in accordance with the general directions.

The articles should be placed in the same pattern for all competitors, but the position of the handler’s article may vary. In case of a horizontal line the handler’s article should not be in an outside position. The dog should be allowed to work approximately half a minute if the working is active and goal driven. There should be six new articles for each competitor.

Directions : Emphasis should be on the dog’s willingness to work and its tempo. If the dog picks up the wrong article once but then brings the correct one, 7 points can be awarded. The exercise is failed, if the dog is allowed to scent or touch the article before it is handed back to the steward, if commands are given when the dog is at the articles, or if the dog picks up a wrong article twice.

Dropping the article:

If the dog drops the article, but picks it up on its own initiative, not more than 7 points can be awarded. If an extra “retrieve” command has to be given before the dog picks up the dropped article, the maximum is 5 points. If the dog drops the object beside the handler and the handler picks it up without taking a step, 5 points can be awarded presuming the dog takes the heel position correctly. If the object is dropped, due to the handler’s carelessness after the release command, not more than 7 points can be awarded.

Chewing or biting on the article

Chewing or biting on the article is penalised by a reduction of 2-3 points. If chewing is extensive not more than 5 points can be awarded. Very extensive chewing or breaking the article results in failing the exercise (0 points). No penalty should be given, however, if the dog once takes a better grip of the article.

EXERCISE 8.

Distance control

[Coeff . 4]

Commands: “Down” “Stay”, “Sit”, “Stand”, “Down” and /or hand signals.

Performance: The dog is commanded in down position at the starting point. When instructed, the handler leaves the dog and moves to an assigned place approx. 10 m from the dog facing towards the dog. The dog should change positions 6 times (sit / stand / down) according to the handler’s commands. It should remain in its original place. The order of taking the positions should always be sit - stand - down or stand - sit - down and thus the last command for changing position should be “down”. The steward shows the handler in which order the dog should change position with written signs or drawings or an electric display board. The steward should stand approximately 3-5 m from the dog so that he is not able to see the dog when displaying the instructions. The steward should change the sign about every 3 seconds. The handler may use both voice commands and hand signals, but they must be short and used simultaneously. A boundary is marked in back of the dog by an imaginary line connecting two markers. The order of the positions should be the same for all competitors.

Directions: Emphasis should be on the speed at which positions are changed, the clearness of the positions and how well the positions are held and how much the dog moves. To any get points, the dog should not move in total more than one body lengths from the starting point (in any direction). All movements are summed. If the dog misses one position of the six, not more than 7 points should be given and if it misses two positions not more than 5 points should be given. Thus if the dog jumps over one position and takes the next position instead, not more than 5 points can be awarded. If the dog moves one body length it cannot score more than 5. The dog has to change position at least 4 times on command to get points. If the dog sits up before the handler returns, not more than 8 points should be given. Extensive use of voice and exaggerated or long-lasting hand signals are penalised. A second command is -1p. A third command on a position fails this position. The exercise is failed if the dog moves more than one body length.

EXERCISE 9.

Jumping over a hurdle and retrieving a metal or wooden object

[Coeff . 3]

Command : “Jump”, “Retrieve” and “Release” (“Heel”)

Performance: The handler is placed in front of a hurdle at a distance of approx. 2 - 4 m from the hurdle with the dog sitting in heel position. The handler throws a metal or wooden dumbbell over the hurdle. When instructed, the handler commands the dog to jump over the hurdle, retrieve the dumbbell and jump back. The “retrieve” command should not be given later than when the dog starts his jump.

Three different sizes (and weights) of metal and wooden dumbbells must be available, in proportion to the sizes of the dogs. The maximum weight of the largest dumbbell is approximately 200 g for the metallic and 450 g for the wooden. It is, however, the handler’s choice, which dumbbell he / she selects, regardless of the size the dog. The hurdle should be 1 m wide and approximately as high as the dog at the withers, rounded off to the closest 10 cm. It should never be more than 70 cm high.

Directions: The exercise begins in heel position and ends in heel position when the dog has released the dumbbell and the steward has announced ”exercise over”.

If the dog has to search for the dumbbell for a moment, no points should be reduced, if it is working actively. If the dog touches the hurdle even slightly when jumping, the maximum score is 8 points. If the dog supports itself on the hurdle or if it does not jump both back and forth, the exercise is failed. If the hurdle falls over, the exercise is failed. If the dog anticipates the command 2-4 points should be reduced. If the dog leaves as the dumbbell is thrown, the exercise is failed.

Dropping the dumbbell:

If the dog drops the dumbbell, but picks it up on its own initiative, not more than 7 points can be awarded. If an extra “retrieve” command has to be given before the dog picks up the dropped dumbbell, the maximum is 5 points. If the dog drops the object beside the handler and the handler picks it up without taking a step, 5 points can be awarded presuming the dog takes the heel position correctly. If the object is dropped, due to the handler’s carelessness after the release command, not more than 7 points can be awarded.

Chewing or biting on the dumbbell

Chewing or biting on the dumbbell is penalised by a reduction of 2-3 points. If chewing is extensive not more than 5 points can be awarded. Very extensive chewing or breaking the dumbbell results in failing the exercise (0 points). No penalty should be given, however, if the dog once takes a better grip on the dumbbell.

EXERCISE 10. General impression

[Coeff . 2]

Directions: When judging the general impression the dog’s willingness to work and obey the commands are essential. Accuracy and precision are important, as well as natural movements of both handler and dog. To get a high score both handler and dog must work well as a team, show mutual enjoyment of working together and good sportsmanship. The activities during and between the exercises influence the score for the general impression.

If the dog is out of control and leaves the handler during or between the exercises, but stays in the ring no points can be awarded for the general impression. If the dog relieves itself in the ring, the dog is disqualified.

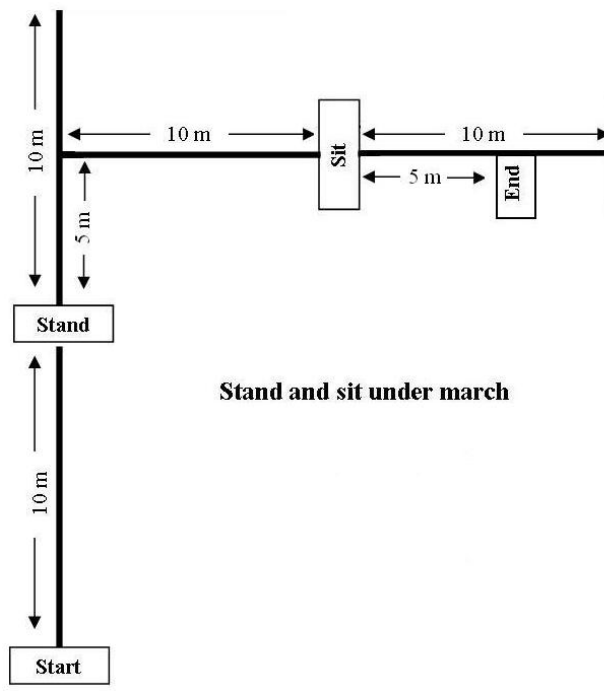
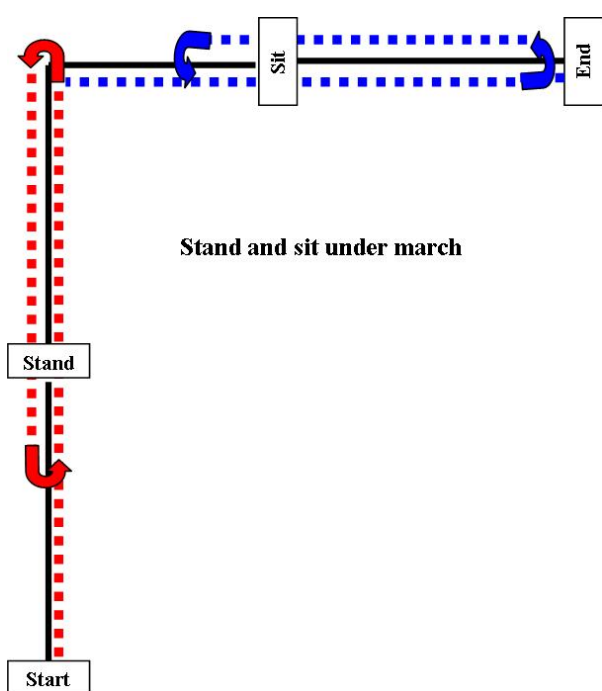

Class 2, exercise 3

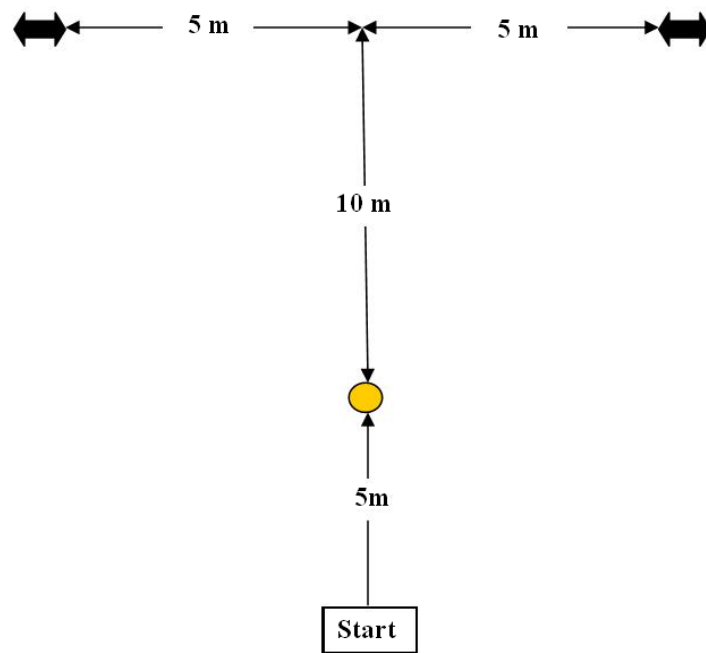

Class 2, exercise 5

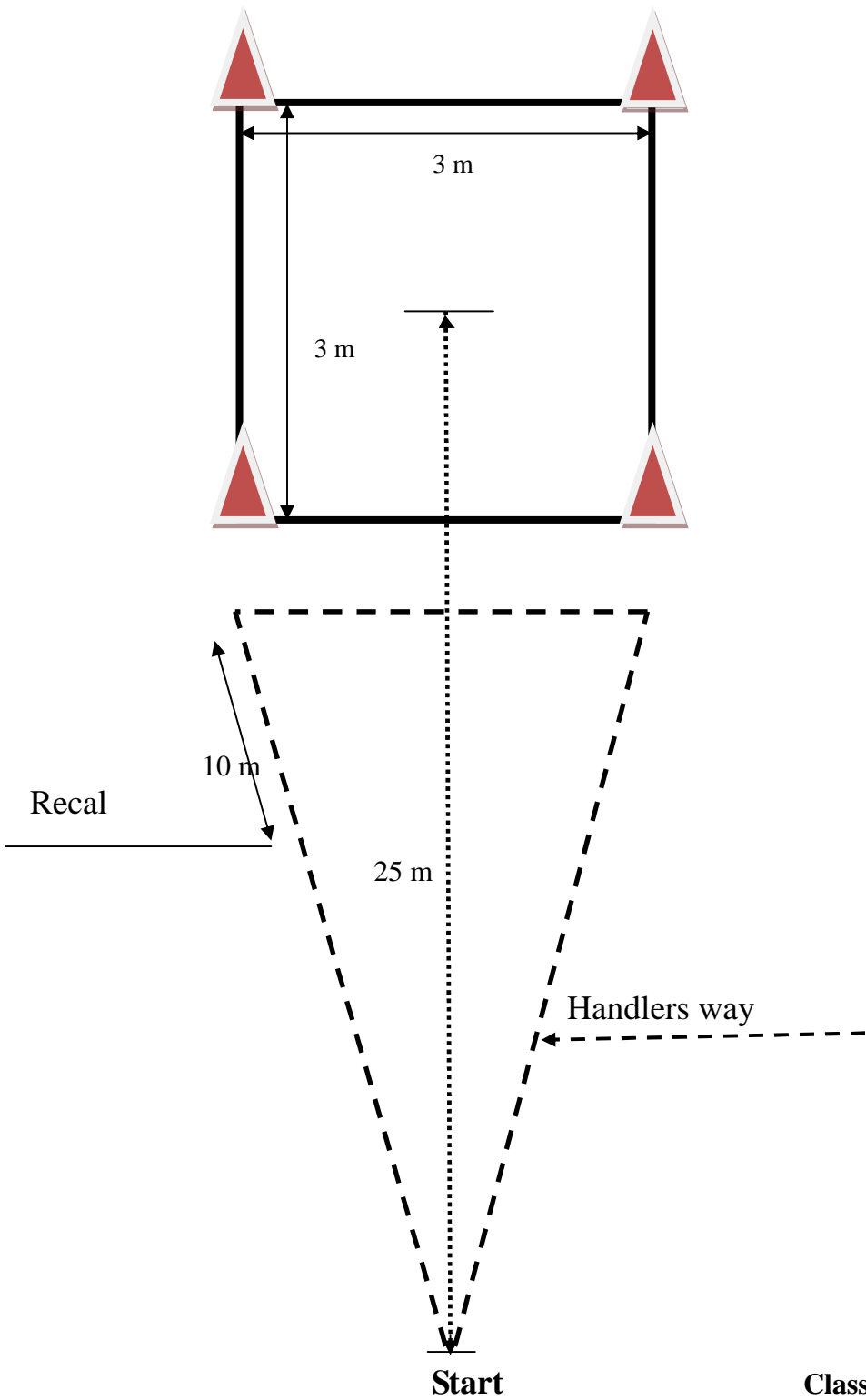

Class 2, exercise 6

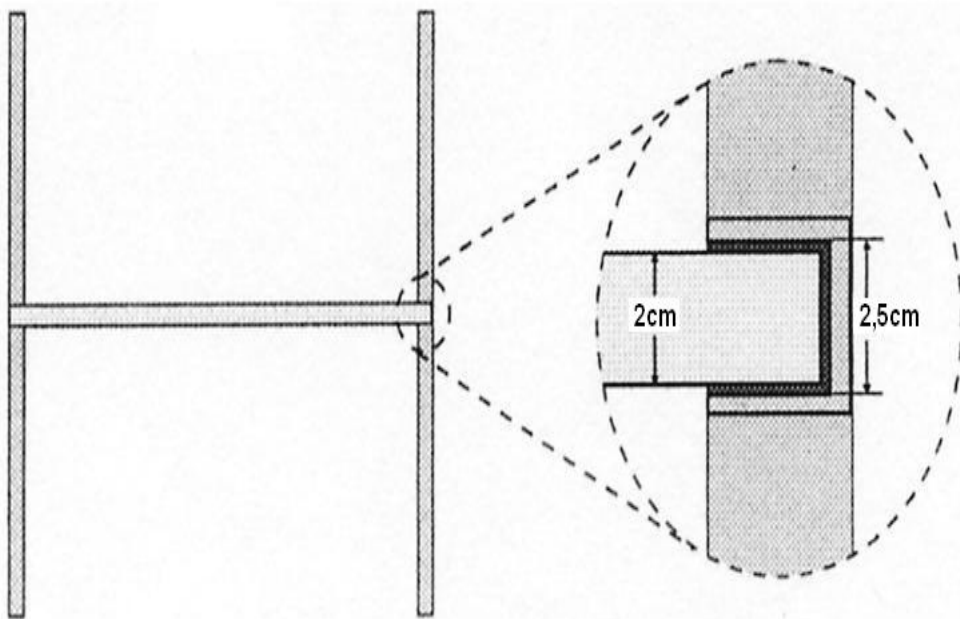
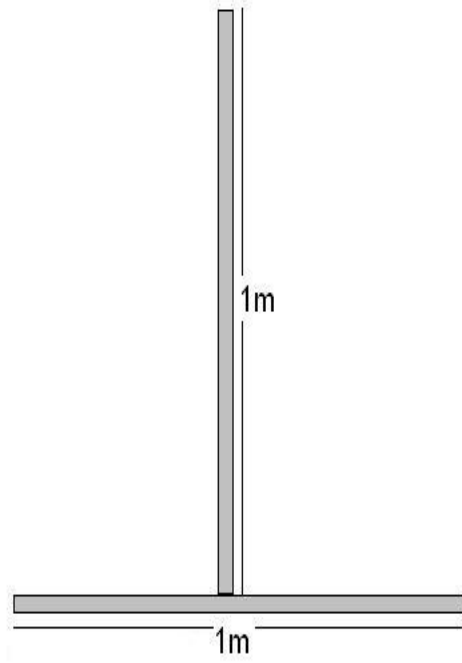
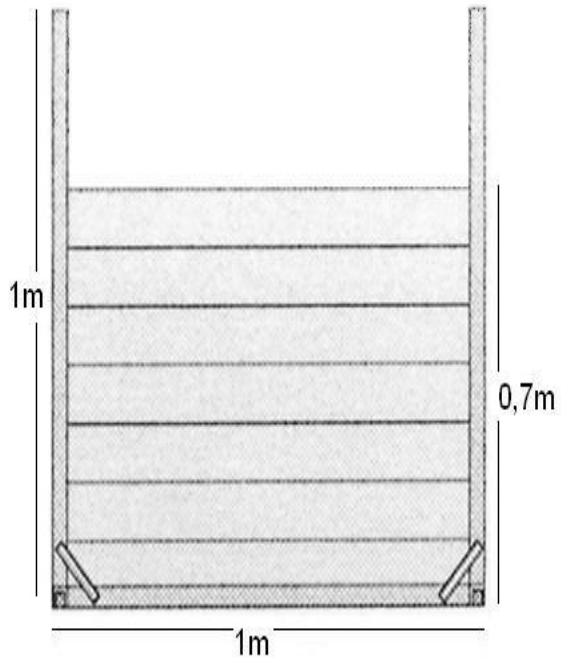

Exercise 9 classes 1 and 2